

MAIN CHORDS 3.0" OD x 0.250" -> REF.3_250

DIAGONALS 1.9" OD x 0.200"

**CONNECTION
STYLE** Pin Ø1" / Spigots

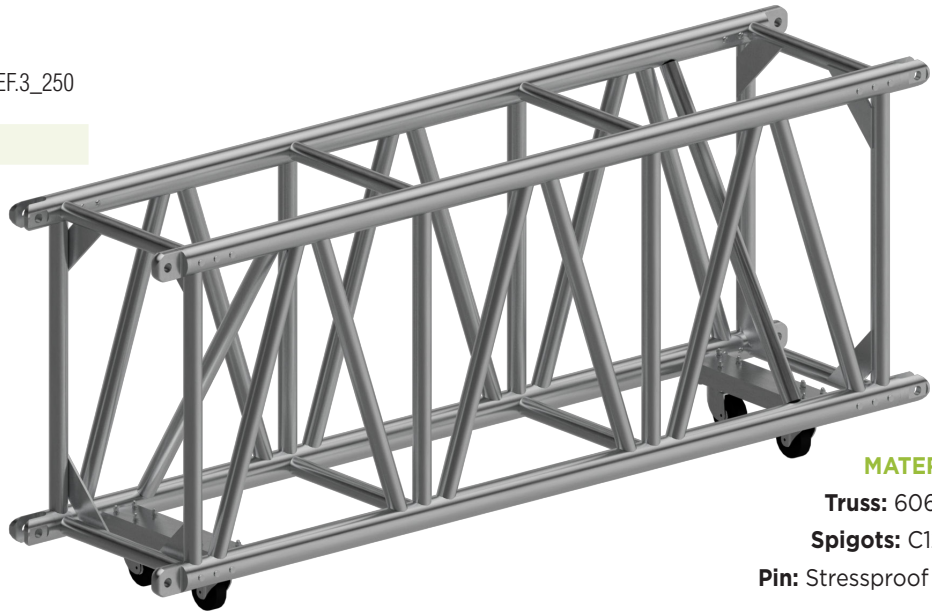

MATERIAL

Truss: 6061-T6

Spigots: C12L14

Pin: Stressproof 1144

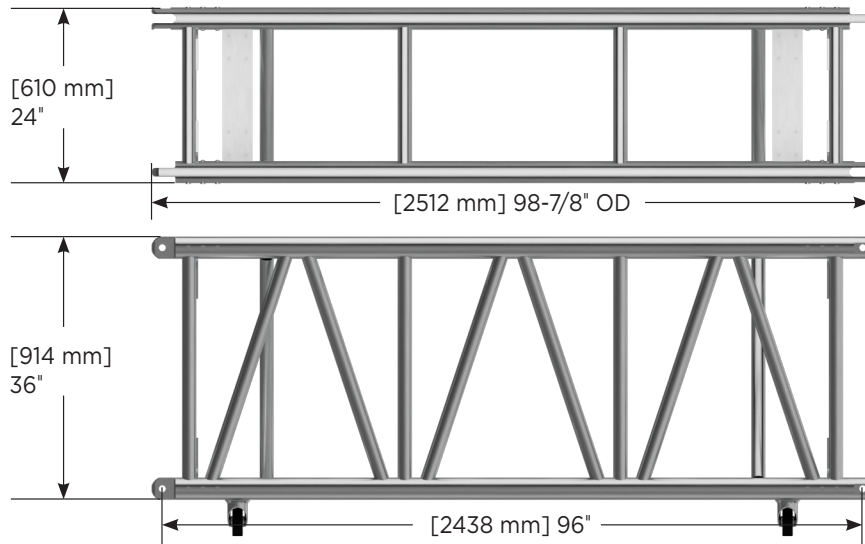
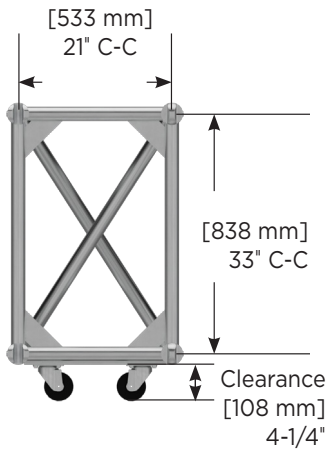

**MAIN CHORDS
3.0" OD x 0.250"**

| Weight lbs | (kg) | Item References | LENGTH* |
|---------------|-------|------------------------|------------|
| 104 | (47) | TIP- 3624 -048 F.3_250 | <- 48" -> |
| 115 | (52) | TIP- 3624 -060 F.3_250 | <- 60" -> |
| 208 | (94) | TIP- 3624 -096 F.3_250 | <- 96" -> |
| 230 | (104) | TIP- 3624 -120 F.3_250 | <- 120" -> |

*Other lengths available: 24, 36, 72 and 84 in. | Custom lengths available upon request.



MANUFACTURED BY CERTIFIED WELDERS

ALLOWABLE LOAD TABLE

| Span Length ft (m) | | Uniformly Distributed Load | | | | Center Point | | | | Third Point | | | | Quarter Point | | | | | |
|-----------------------|---------|----------------------------|--------|------------|---------|---------------|---------|------------|---------|---------------|---------|------------|--------|---------------|---------|------------|--------|------|---------|
| | | Load Capacity | | Deflection | | Load Capacity | | Deflection | | Load Capacity | | Deflection | | Load Capacity | | Deflection | | | |
| lb/ft | (kg/m) | lb | (kg) | in | (mm) | lb | (kg) | in | (mm) | lb | (kg) | in | (mm) | lb | (kg) | in | (mm) | | |
| 8 | (2.44) | 3454 | (5140) | 27633 | (12534) | 0,01 | (0.3) | 27633 | (12534) | 0,02 | (0.5) | 13831 | (6274) | 0,02 | (0.5) | 9221 | (4182) | 0,02 | (0.4) |
| 10 | (3.05) | 2628 | (3910) | 26276 | (11919) | 0,02 | (0.6) | 26276 | (11919) | 0,04 | (1) | 13159 | (5969) | 0,03 | (0.8) | 8773 | (3979) | 0,03 | (0.8) |
| 16 | (4.88) | 1630 | (2425) | 26077 | (11828) | 0,10 | (2.6) | 26077 | (11828) | 0,16 | (4.1) | 13093 | (5939) | 0,14 | (3.5) | 8728 | (3959) | 0,13 | (3.2) |
| 20 | (6.1) | 1295 | (1927) | 25894 | (11745) | 0,20 | (5) | 25894 | (11745) | 0,31 | (7.9) | 13031 | (5911) | 0,27 | (6.8) | 8687 | (3941) | 0,25 | (6.3) |
| 24 | (7.32) | 1070 | (1592) | 25673 | (11645) | 0,34 | (8.5) | 21866 | (9918) | 0,46 | (11.6) | 12956 | (5877) | 0,46 | (11.7) | 8637 | (3918) | 0,43 | (10.9) |
| 30 | (9.14) | 842 | (1254) | 25269 | (11462) | 0,65 | (16.5) | 17352 | (7871) | 0,71 | (18.1) | 12818 | (5814) | 0,89 | (22.7) | 8546 | (3876) | 0,83 | (21.1) |
| 32 | (9.75) | 785 | (1168) | 25117 | (11393) | 0,79 | (20) | 16217 | (7356) | 0,81 | (20.6) | 12163 | (5517) | 1,03 | (26.2) | 8109 | (3678) | 0,96 | (24.4) |
| 40 | (12.19) | 610 | (909) | 24420 | (11077) | 1,51 | (38.3) | 12787 | (5800) | 1,27 | (32.3) | 9590 | (4350) | 1,61 | (40.9) | 6393 | (2900) | 1,50 | (38.1) |
| 48 | (14.63) | 436 | (649) | 20930 | (9494) | 2,27 | (57.7) | 10465 | (4747) | 1,84 | (46.8) | 7849 | (3560) | 2,32 | (58.9) | 5233 | (2373) | 2,16 | (54.9) |
| 50 | (15.24) | 400 | (595) | 19991 | (9068) | 2,46 | (62.6) | 9996 | (4534) | 2,00 | (50.8) | 7497 | (3400) | 2,51 | (63.9) | 4998 | (2267) | 2,35 | (59.6) |
| 56 | (17.07) | 313 | (466) | 17554 | (7963) | 3,09 | (78.5) | 8777 | (3981) | 2,52 | (64) | 6583 | (2986) | 3,15 | (80.1) | 4389 | (1991) | 2,95 | (74.9) |
| 60 | (18.29) | 270 | (401) | 16183 | (7341) | 3,55 | (90.1) | 8092 | (3670) | 2,90 | (73.7) | 6069 | (2753) | 3,62 | (91.9) | 4046 | (1835) | 3,38 | (86) |
| 64 | (19.51) | 234 | (348) | 14971 | (6791) | 4,04 | (102.5) | 7485 | (3395) | 3,31 | (84) | 5614 | (2546) | 4,12 | (104.5) | 3743 | (1698) | 3,85 | (97.9) |
| 70 | (21.34) | 191 | (285) | 13389 | (6073) | 4,83 | (122.6) | 6694 | (3037) | 3,98 | (101) | 5021 | (2277) | 4,92 | (125) | 3347 | (1518) | 4,62 | (117.2) |
| 72 | (21.95) | 179 | (267) | 12915 | (5858) | 5,11 | (129.7) | 6457 | (2929) | 4,22 | (107.1) | 4843 | (2197) | 5,21 | (132.2) | 3229 | (1464) | 4,88 | (124.1) |
| 80 | (24.38) | 140 | (209) | 11228 | (5093) | 6,31 | (160.2) | 5614 | (2547) | 5,24 | (133.1) | 4211 | (1910) | 6,42 | (163.2) | 2807 | (1273) | 6,04 | (153.4) |

Load per applied point

NOTES

- Capacities shown in this table are valid for structures manufactured after January 2020.
- Trusses must be loaded uniformly on both sides of their longitudinal axis.
- Loads must be applied to or as close as possible to the nodes of the trusses.
- Deflection of truss is theoretical and based solely on their rigidity. It therefore does not take into account the possible movement between the truss sections due to the tolerance of the pins/bolts.
- Data are valid for indoor use only.
- Trusses are hung from the top chord only.
- Data are valid only for static loads and span, with two support points (one at each end).
- If dynamic loads or more attachment points are needed, contact **Therio Innovation**.

